

Data sheet



Application

Integrated presetting valves

- for normal volume flows: type RA-N 013G0372
- for small volume flows: type RA-U 013G0373

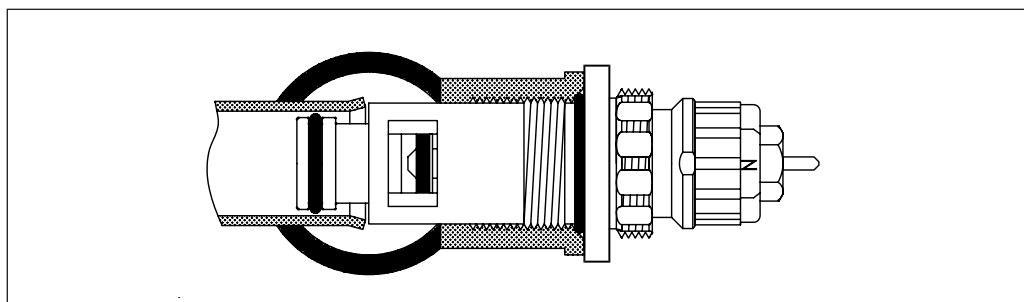

Integrated valves, type RA-N (013G0372) and RA-U (013G0373), with built-in presetting are designed for incorporation into valve radiators from different radiator manufacturers.

The two valve types can be recognised by the colour of the presetting ring:

- Red: RA-N
- Yellow: RA-U

Integrated valves can be used in single and two pipe installations with circulating pump.

The gland seal of the valve can be replaced while the system is in operation.

To avoid calcification and corrosion, it is important for the composition of the circulating water to comply with the VDI 2035 guidelines.

Danfoss thermostatic sensors types RA 2000 and RAW with patented snap sockets as well as Danfoss thermo-hydraulic actuators can be installed directly onto the integrated valve.

Code nos. and technical data

Code no.	Conne- ction thread	Presetting									Max. water temp. °C	Differential pressure ³⁾		Test press. bar	Work. press. bar	
		k _v -value ¹⁾²⁾										k _{vs}	Rec. bar			Tech. bar
		1	2	3	4	5	6	7	N	N						
013G0372	G ½ A	0.14	0.21	0.26	0.32	0.46	0.59	0.73	0.87	1.05	120	0.05- 0.2	0.6	16	10	
013G0373	G ½ A	0.04	0.05	0.07	0.09	0.13	0.18	0.24	0.34	0.55						

¹⁾ k_v-values indicate the flow volume (Q) in m³/h at a pressure loss (Δp) across the valve of 1 bar. $k_v = Q / \sqrt{\Delta p}$. At setting N, the k_v-value in accordance with EN 215 can be stated as Xp = 2 K. At lower preset values, Xp will be reduced until approximately Xp 0.5 at presetting 1. The table shows the average measured values for integrated valves with radiator. The k_{vs}-values indicate the valve capacity, when the valve is fully open.

²⁾ When using a liquid filled radiator thermostat e.g. RAW, RAS-D or remote setting element type RA 5060 Xp will be increased by factor 1.6 (at setting "N", ref. EN 215).

³⁾ The technical differential pressure indicates the upper limit for a proper valve function. In most two-pipe systems the recommended differential pressure is sufficient. In order to achieve a noiseless function we recommend in smaller systems to apply automatic bypass valves or automatic balancing valves. If pump differential pressure exceeds the recommended max. valve differential pressure it is recommended that an automatic balancing valve type ASV-P/PV is added to the system.

Spare parts and accessories

Product	Code no.
Gland seal, 10 pcs. ¹⁾	013G0290
Red protection cap for RA-N valve 013G0372	013G0951
Yellow protection cap for RA-U valve 013G0373	013G0952
Small O-ring	633B1427
Big O-ring	633B0387

¹⁾ The gland seal of the valve can be replaced under pressure, i.e. while the installation is in operation.

Design and dimensions

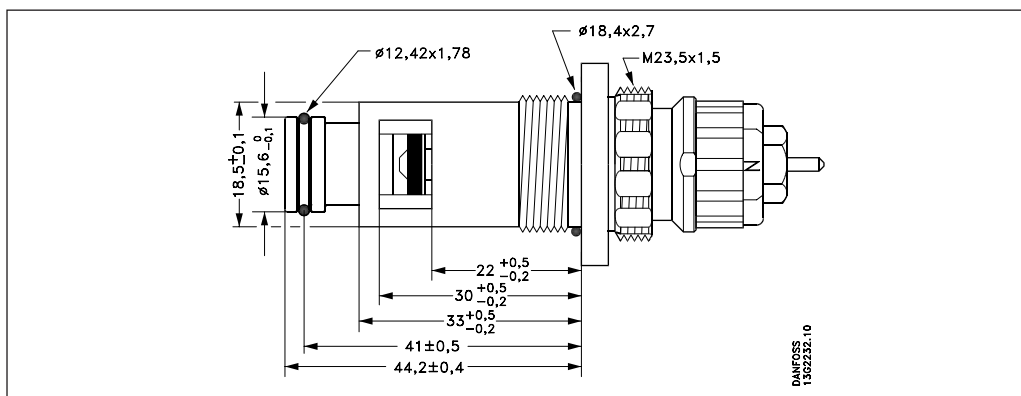

Materials

Part	RA-N 013G0372	RA-U 013G0373
Valve body	Ms 58	Ms 58
Valve seat	PPS	Ms 58
Throttle nozzle	PPS	PPS
Setting dial	Plastic	Plastic
O-ring	NBR / EPDM	NBR / EPDM
Valve spindle	PPS	Ms 58
Valve cone	NBR	NBR
Pressure pin and valve spring	Chrome steel	Chrome steel

Presetting

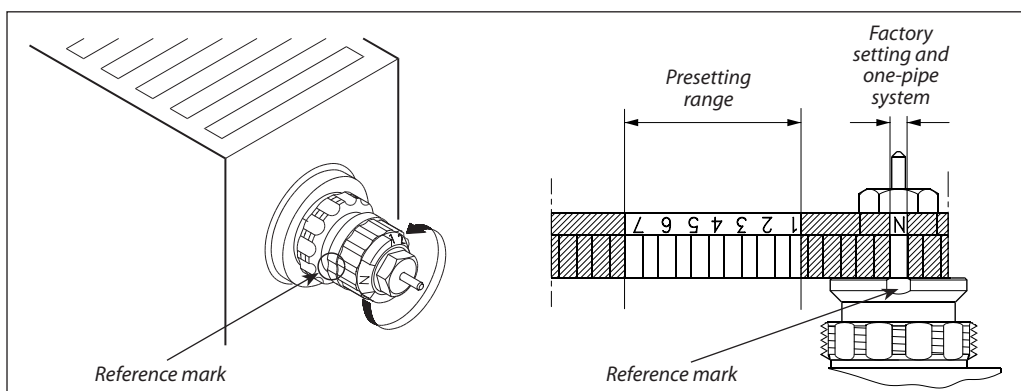

The presetting values of the integrated valves can be adjusted easily and accurately without the use of tools (factory setting: 'N'):

- Remove the protective cap or the thermostatic sensor
- Find the reference mark
- Turn the setting ring until the desired presetting aligns with the reference mark.

The presetting is controlled directly without the use of equipment. After installation in the radiator, the reference mark of the valves will not always be positioned in the same place.

Presetting can be selected infinitely variably within the range of 1 to 7. At setting 'N' the valve is fully open. Setting in the shaded areas of the drawing should be avoided.

In a one-pipe installation, the setting 'N' must be used.

Setting 'N' can be used as a flushing position if the system has to be flushed out because of dirt problems.

When the radiator thermostat has been installed, the presetting is protected against unintended regulation.

For Danfoss elements RA 2000 and RAW, a theft protection device is available; this also provides added security against unwanted adjustment of the preset values.

Capacities without radiator and fittings

RA-N 013G0372

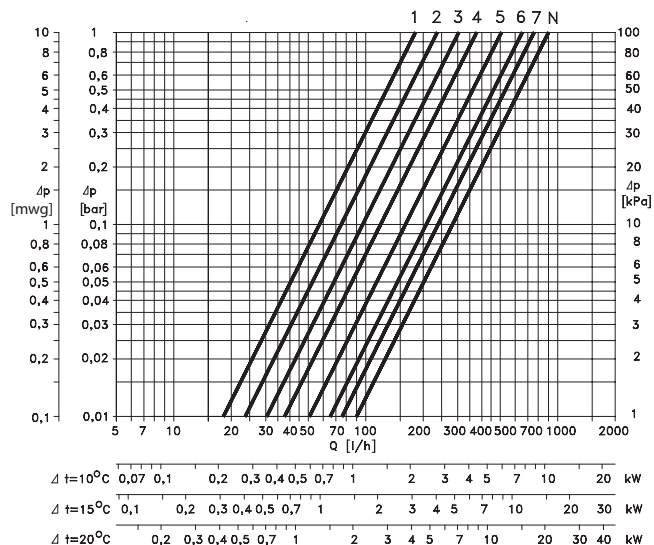

RA-U 013G0373

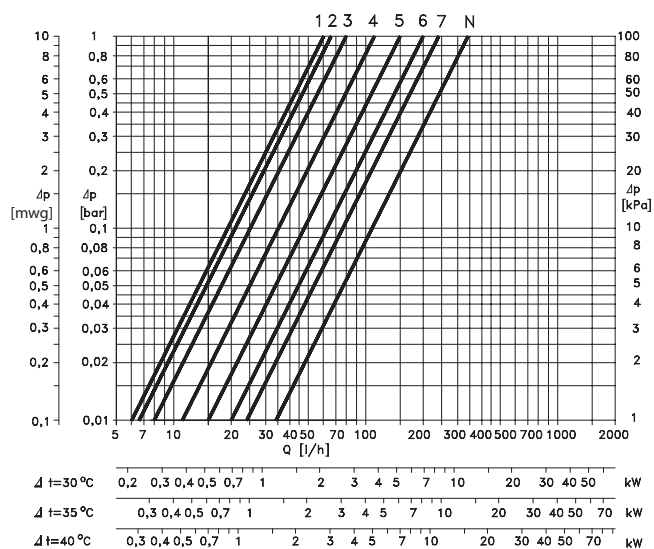

Capacities at Xp = 2K with Danfoss radiator thermostat RA 2000 are measured without radiator and connection fittings.

Dimensions

Standard fittings

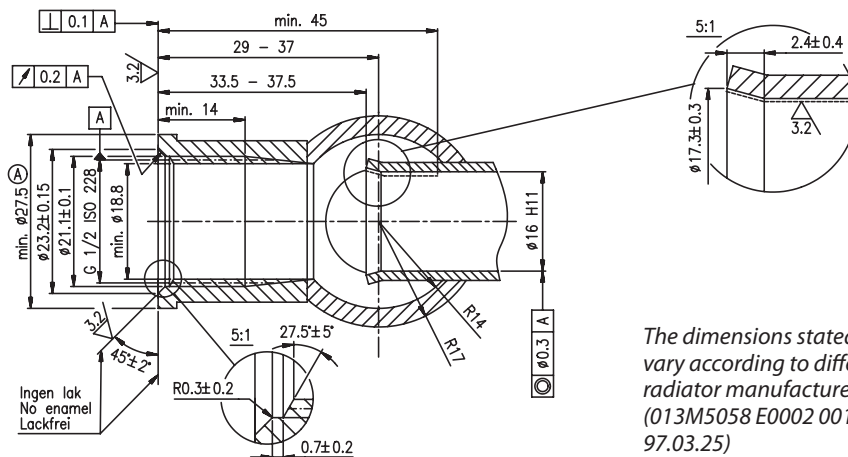

The dimensions stated may vary according to different radiator manufacturers. (013M5058 E0002 001 047 97.03.25)

Mounting instructions

Installation of an integrated valve at radiator manufacturer's plant

An integrated valve can only be fitted once in a radiator (because of the load on the deformation zone).

- Fit the integrated valve in the radiator using a 12-edge spanner, KW 21.
- Tighten using a torque of 30-35 Nm.
- If required, continue turning until one of the cap thread beads points upwards (only clockwise).

Tolerance for adjustment: $\pm 5^\circ$.

Removal and fitting in an existing radiator

- Before removal: Notice the presetting value.
- Please mark off the valve position on the valve and the radiator, e.g. on top.
- Remove valve.
- Fitting: Insert the integrated valve, tighten until the marked-off position has been reached.

Setting ring with presetting numbers:

- Red: RA-N
- Yellow: RA-U

Replacement of the gland seal

While the system is in operation, the gland seal can be replaced by means of a spanner, KW 10. Hold the setting ring using a 12-edge ring-spanner, KW 17.

Danfoss can accept no responsibility for possible errors in catalogues, brochures and other printed material. Danfoss reserves the right to alter its products without notice. This also applies to products already on order provided that such alterations can be made without consequential changes being necessary in specifications already agreed. All trademarks in this material are property of the respective companies. Danfoss and the Danfoss logotype are trademarks of Danfoss A/S. All rights reserved.



Danfoss A/S
 Haarupvaenget 11
 Haarup
 DK-8600 Silkeborg
 Telefon: +45 7488 8000
 Telefax: +45 7488 8100